

# Antioxidant and Anti-Microbial Properties of *Euphorbia condylocarpa* Roots under Hot-air Drying Conditions

Afsaneh Mohammadi and Akbar Arabhosseini\*

Department of Agrotechnology, College of Abouraihan, University of Tehran, Tehran, Iran

\*Corresponding author: ahosseini@ut.ac.ir

Article History: Received: 28 September 2022/Accepted in revised form: 21 July 2023

© 2012 Iranian Society of Medicinal Plants. All rights reserved

## ABSTRACT

Drying kinetics of roots of *Euphorbia condylocarpa* plant was studied. The root slices were dried at four temperature levels, also in shadow as control in three replications. The dried samples were considered for evaluation the total phenolic compounds (TPCs), free radical scavenging capacity inhibitory 2, 2-diphenyl-1-picrylhydrazyl, inhibiting gram-negative and gram-positive bacteria of *Pseudomonas aeruginosa*, and *Staphylococcus aureus*. The obtained results were compared with control treatments. The analysis of variance showed a significant difference in 1% level for the main effects of temperature, thickness and their interaction on drying time, TPC and changes of inhibiting *Pseudomonas aeruginosa* and *Staphylococcus aureus*. The results indicated that the highest content of total phenolic compounds were obtained at 40 °C, and 7 mm, and increasing the free radical scavenging capacity of 2, 2-diphenyl-1-picrylhydrazyl was achieved at 60 °C, and 7 mm. In addition, the highest inhibition zone values for the gram-positive bacterium of *Staphylococcus aureus* was obtained for the samples dried at 50 °C and thickness of 7 mm while the highest inhibition zone values for gram-negative bacterium of *Pseudomonas aeruginosa* was obtained at 50 °C and 3 mm thickness.

**Keyword:** Antioxidant properties, DPPH, *Euphorbia condylocarpa*, Hot-Air Drying kinetics, total phenolic compounds

## INTRODUCTION

In recent decades, medicinal plants gained global importance [1]. Human health has been inextricably linked to the use of herbal medicines [2]. The use of medicinal plants remains the primary source of healthcare for majority of people in most of developing countries [3]. Plants with therapeutic and pharmacological properties are commonly classified as “medicinal plants” [4]. Medicinal plants are broadly used by the elderly and global communities with limited access to health centers. The *Euphorbiaceae* family is the largest family of angiosperm that are classified as annual plants and one of the important families of medicinal plants worldwide with 300 genera and 8000 types, which are comparable with five genera, and 72 types in Iran [5]. One of the most important types of *Euphorbia* family is "*Euphorbia condylocarpa*" with Iranian Kurdish name of "*Shoaleh Koleh*" that is distributed in Turkey, Iraq, and the west regions of Iran [6]. The biodiversity of different varieties of this plant has been reported in numerous regions of Iran, including provinces of Kurdistan, Guilan, Chaharmahal Bakhtiari, Lorestan, and Kermanshah. This plant has an underground simple stem created from the fusiform huge tuber. Medicinal plants have antioxidant properties mainly due to the presence of phytonutrients and ingredients such as phenols, flavonoids, and terpenoids [7]. The environmental stresses in the natural habitats of wild plants enhance them to synthesize active ingredients with high therapeutic potential like phenolics and flavonoids that possess distinguished antioxidant activity and therapeutic effects [8]. The medicinal properties of the *Euphorbia condylocarpa* are the antioxidant flavonoids, particularly flavones, anticancer effects, anti-inflammatory, anti-bacterial, wart treatment, reduction of the risk of blood cancer and osteoporosis, and wound healing properties [6]. The results showed that methanol extracts of *Euphorbia Condylocarpa* root can be proposed as an antibacterial agent and it can be further assessed to discover bioactive natural products involved in its activity [9]. The antibacterial and cytotoxic activities of several *Euphorbia* species have been reported in different studies. Furthermore, studies revealed that *Euphorbia* species extracts possess significant anti-inflammatory, analgesic, haemostatic and wound healing properties [10].

\*Corresponding author: ahosseini@ut.ac.ir

Email Address: College of Aburaihan, University of Tehran, Tehran, Iran

Medicinal and aromatic plants, according to their use, can be marketed as fresh or dried products. Medicinal plants are also used as raw materials for the manufacture of medicines marketed by the pharmaceutical industry [11]. Therefore, since these plants have many medicinal properties, they should be saved and consumed with the highest nutritional values [12]. Natural products have been the source of most active ingredients of medicines. The active ingredients sourced from herbs are increasingly valued as raw materials in the preparation of modern medicines and herbal preparations [13]. Accordingly, it has been stated that the drying method is the most important and well-known technique to preserve plant materials [14] because it decreases the moisture content in fresh samples for long-term storage [15]. Nguyen and Duong Le [16] revealed that the drying process is a crucial stage to provide dried samples for further examination and other applications. Also, it has been offered that the main purpose of drying medicinal plants is used to extend product shelf life, minimize packaging requirements, reduce shipping weights, elimination of water [1] and to stop the proliferation and development of microorganisms and preserve the quality of agricultural products [17]. These methods have already been applied to reduce the moisture content of some medicinal and aromatic plants and their effects on yield and composition of essential oil by other researchers, such as *Matricaria recutita* L., *Satureja hortensis* L. [18], *Ocimum basilicum* L. [12] *Laurus nobilis* L. [19], and *Mentha longifolia* L. [20]. Various drying systems are applied for drying of medicinal and aromatic plants, such as hot air dryer, fixed-bed dryer, belt dryer, fluidized bed dryer, freezer dryer, oven dryer, vacuum dryer, microwave dryer, and infrared dryer [21, 22]. One of the most common dryers is fixed-bed (batch) dryer. Several parameters such as drying temperature, moisture content, slice thicknesses, air humidity, and air velocity influence on drying process. It is required to define the experiment under a controlled condition for the prediction of drying time of the products and detection of the moisture-time curve (moisture-time reduction rate). Some researchers suggested that the study of drying kinetics is one of the appreciate methods to control the drying time and drying conditions. Hence, given that the moisture of samples changed by process time, the kinetic of the drying process should be evaluated [23].

Accordingly, despite the numerous studies concerning the effects of drying method on anti-microbial and anti-bacterial activities of various plants, there was no documented study about the effects of hot-air drying method on *Euphorbia condylocarpa*. Therefore, the present study aimed to investigate the effects of hot air drying on the drying kinetics and also anti-microbial and anti-bacterial activities of *Euphorbia condylocarpa*.

## MATERIALS AND METHODS

### Sample Preparation

The *Euphorbia Condylocarpa* plants were collected from mountains area of Kurdistan province, Iran. The fresh plants were harvested and washed thoroughly in distilled water. Plant tubers were collected and stored in a bottle for drying experiments. For determining the initial moisture content of the samples, tubers were cut in slices and certain amount of slices were placed in an oven at temperature of 104°C for 48 h, and then the moisture content of the sample was calculated using Eq. 1:

$$MC = \frac{W_m - W_d}{W_d} \times 100 \quad (1)$$

Where, MC is the moisture content (%),  $W_m$  is initial mass of samples and  $W_d$  is the mass of dried samples.

### Drying Conditions and Experimental Setup

The samples were weighed by using a stationary balance (AND, Japan) with an accuracy of 0.01 g, which was close to the dryer and the time interval for each measurement was less than 6 s. The weight of the samples was measured every 5 min during the drying process while the drier was running continuously. The drying experiments continued until the mass between two weighing samples was less than 0.05 g.

Comprehensive information on the experimental system and its design are provided by Aghbashlo *et al.* [24]. A laboratory-scale hot-air dryer consists of an adjustable centrifugal blower, air heating chamber (4.5 kW), drying chamber, system controller, inverter (Lenze 8300, GmbH, and co KG Aerzen, Postfach, Germany) and sample tray (Fig. 1).

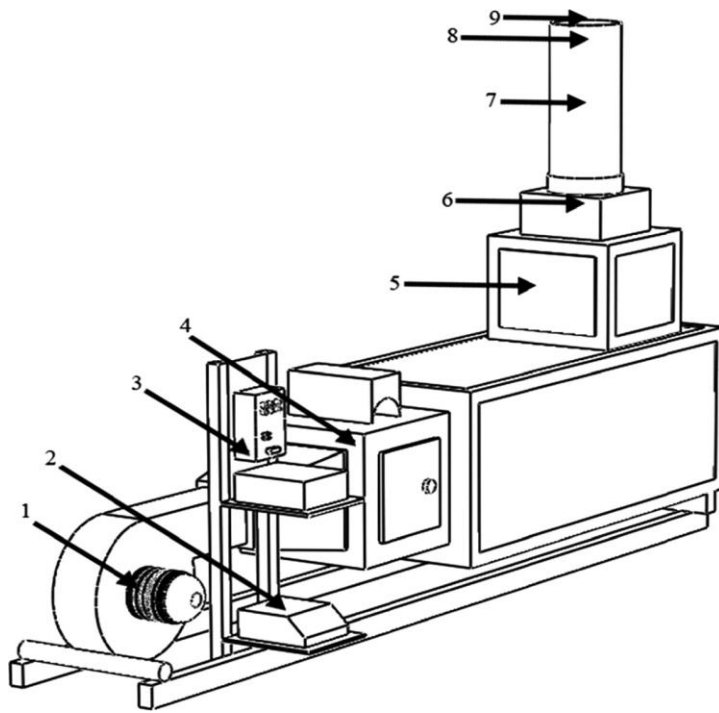

**Fig. 1** Schematic view of the experimental equipment: 1. Inverter, 2. Fan, 3. Heaters, 4. Heaters control unit, 5. Air tunnel, 6. Thermocouples, 7. Anemometer, 8. Fluidization cylindrical chamber, and 9. Chamber.

The experiments were performed at four air temperatures of 30, 40, 50 and 60°C at a constant air velocity of 1 m.s<sup>-1</sup>. During the experiments, the air relative humidity was in the range of 35-42% while the ambient temperature was in the range of 18-23°C. The drying chambers and tunnel length were insulated with rock wool and wood to reduce the undesirable effects of temperature and humidity of the ambient air on the drying experiments. The drying tray was also isolated using the glass cylinder and the hot air exits from the upper part of the glass cylinder. The dryer was equipped with an automatic temperature controller with an accuracy of ±0.1°C. The air velocity was controlled by using PROVA AVM-07 anemometer (TES, Co, Taipei, Taiwan) with an accuracy of ±0.05 m.s<sup>-1</sup> and using an inverter, which directly acted on the blower motor (1.5 kW). The hot air orientation was vertically upward to the samples. At the start of each experiment, the *Euphorbia condylocarpa* root slices were washed and cut using a mechanical cutter into circle forms having diameters of about 3, 5 and 7 mm. Drying experiments were repeated three times. The temperature of the chamber was fixed by a temperature controller with an accuracy of ±1°C, the drying system was run for 30 to 40 min until the desired drying air temperature was achieved.

The dimensionless moisture ratio (MR) of *Euphorbia Condylocarpa* roots was calculated by using Eq. 2:

$$MR = \frac{M_t - M_e}{M_0 - M_e} \quad (2)$$

Where MR is the moisture ratio (dimensionless),  $M_t$  is moisture content at time t (kg water.kg<sup>-1</sup> dry solid),  $M_e$  is the equilibrium moisture content (kg water.kg<sup>-1</sup> dry solid), and  $M_0$  is the initial moisture content (kg water.kg<sup>-1</sup> dry solid).

Considering that the values of  $M_e$ , which was relatively small than the values of  $M_t$  or  $M_0$ , thus, the moisture ratio was calculated by Eq. 3:

$$MR = \frac{M_t}{M_0} \quad (3)$$

## Extraction

According to the method, described by Mohammadi *et al.*, [5], 4 g of dried *Euphorbia condylocarpa* roots (Fig. 2) was powdered and placed in a closed plastic bag. Then, the samples were subjected for extraction with 40 ml

methanol (Merck, Germany) by using the Soxhlet apparatus at 60 °C for 12 h. The resulted extracts were filtered and concentrated by using a rotary evaporator (Heidolph, Laborota 4000, Schwabach, Germany) under reduced pressure at 40°C for four days. Then, the extracts were stored in a refrigerator for investigating the antioxidant and antimicrobial activities.



**Fig. 2** *Euphorbia condylocarpa*, A) Fresh plant, B) Dried and powdered roots

### Antioxidant and Antimicrobial Assay

The total phenolic content of *Euphorbia condylocarpa* roots was determined with slight modifications. Accordingly, 1 g of the *Euphorbia condylocarpa* root powder was blended with one ml of 6M HCl and five ml of 75% methanol/water solution in a screw-capped tube. Then, the tube was vortexed and put in a water bath at 90 °C. Immediately, the solution was agitated for two hours, and chilled at room temperature. Then the obtained solution was reached to 10 ml volume by adding distilled water. One ml of this solution was mixed with five ml of 9-fold diluted Folin and Ciocalteu reagent. Fifteen ml of carbonate sodium, with concentration of seven grams per 100 ml, was added to this compound. The mixture was diluted to 100 ml with distilled water and shaken as well. The absorbance versus prepared blank was read at 760 nm until it reached to a uniform state. Final results were expressed as mg catechin equivalent per 100 ml of *Euphorbia condylocarpa*.

In this study, different concentrations of methanolic 2, 2-diphenyl-1-picrylhydrazyl (DPPH) solution (Merck, Germany) were first prepared and their absorbance measured at a wavelength of 515 nm using a spectrophotometer (CE model 2502, UK). The standard curve was then obtained. Then, 0.1 ml of *Euphorbia condylocarpa* extract was mixed with 3.9 ml of a methanolic solution (Fig. 3). The absorbance at 515 nm was measured on a UV-Vis spectrophotometer at various time intervals. This was done until the reaction reached a steady state. The  $[DPPH]_{t=0}$  was taken as the concentration of DPPH at 515 nm. Then, 3.9 ml of a 25 mg.l<sup>-1</sup> of methanolic solution was mixed with 0.1 ml of *Euphorbia condylocarpa* extract and the absorbance value after 30 min was read as the  $[DPPH]_t$ . The percentage of remaining DPPH at steady state was calculated using Eq. 4:

$$DPPH \% = \frac{[DPPH]_t}{[DPPH]_{t=0}} \quad (4)$$

Where  $[DPPH]_{t=0}$  is the initial concentration of DPPH, and  $[DPPH]_t$  is the DPPH concentration at steady state. The percentage of remaining DPPH at steady state was plotted against the sample concentration to obtain EC<sub>50</sub> value which is defined as the amount of sample necessary to decrease the initial DPPH concentration by 50%. The EC<sub>50</sub> was expressed as ml sample to gram DPPH. It should be noted that the spectrophotometer device was set by pure methanol as the control sample.

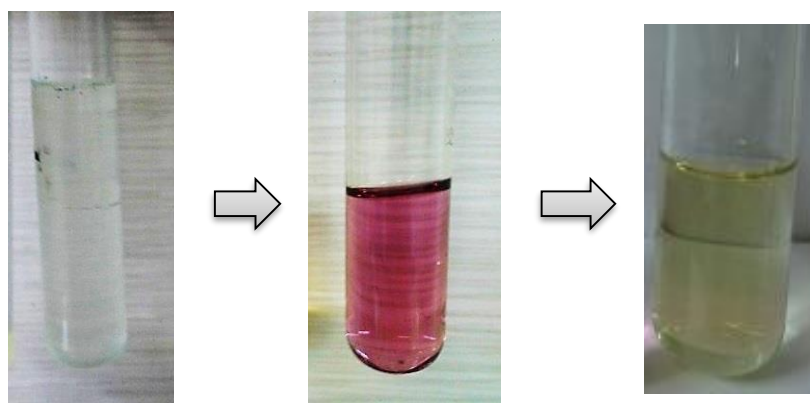

**Fig. 3** DPPH free radical inhibition assay for root extract of *Euphorbia condylocarpa* plant

The antimicrobial activities of the ethanolic extracts of *Euphorbia condylocarpa* were determined based on the agar disc diffusion method against the gram-positive bacterium (*Staphylococcus aureus*) and gram-negative bacterium (*Pseudomonas aeruginosa*). Therefore, 36 g of the Muller Hinton Agar was weighed and dissolved in 100 ml of distilled water in a sterile conical flask. The culture medium was sterilized by autoclaving and then was chilled at room temperature. Then, the mentioned medium was poured into the sterile Petri dish, and 100  $\mu$ l of 18 h culture of both bacteria was adapted to  $1.5 \times 10^8$  CFU.ml<sup>-1</sup> and was spread into a sterile plate. Both microorganisms were inoculated into a 6 mm diameter circular plate with 10  $\mu$ l of plant extract. The cultures were incubated at 37°C for 24 to 48 h. The diameters of the inhibition zones were then measured on a mm scale, with samples less than 5 mm in diameter showing no effect. Finally, the presence or absence of the growth inhibition zone around each disc was compared with the standard antibiotic disc. (Ampicillin Disk, Merck, Germany) [25].

First, 36 g of Muller Hinton Agar medium was weighed and poured into a laboratory conical flask. The medium obtained was then diluted to 1000 cc with distilled water and stirred slowly and carefully using a rod. The solution was then brought to the boil by resistance heating. Finally, to complete the sterilisation process, the above solution was placed in an autoclave at 121 °C and 15 psi pressure for 15 minutes. Finally, the sterilized medium was divided into plates with a diameter of 10 cm, and in a volume of 15 ml. Subsequently, the bacterial suspension (*Staphylococcus aureus* and *Pseudomonas aeruginosa*), equal to 0.5 McFarland turbidity, was cultured on Muller Hinton Agar medium by a sterile swab. After absorbing the moisture of the bacterial suspension, it was created holes with a diameter of 6 mm in the mentioned medium, and 100  $\mu$ l of each extract were separately injected into the shaped holes, together with negative control (solvent). Also, 200  $\mu$ l of ethanol 60%, as a solvent, was added to a quarter of the obtained ethanolic extract of *Euphorbia condylocarpa* root.

### Statistical Analysis

A factorial experimental design was used for experiments in this research. Data analysis (ANOVA) was performed by SAS software (ver. 9.1), and the mean values were compared by Duncan's Multiple Range Test at  $P < 0.05$ . Also, the charts were drawn using Excel software.

## RESULTS AND DISCUSSION

### Temperature and Thickness Effects

Analysis of variance showed a significant effect difference at ( $p < 0.01$ ) for temperature, thickness, and their interaction on drying kinetics.

In these experiments, the roots of *Euphorbia condylocarpa* were tested with thin-layer drying processes of *Euphorbia condylocarpa* root slices at constant air velocity of 1 m.s<sup>-1</sup> and at temperatures of 30, 40, 50, and 60°C (Fig. 4). Since the drying time was affected by thickness, temperature, and their interaction ( $p < 0.01$ ), the obtained results showed that the drying time increased by increasing thickness and decreasing temperature so that the

longest time of drying process was obtained at 30 °C and 7 mm thickness, and the shortest drying time was achieved at 60 °C and 3 mm thickness. By increasing the slice thickness, the distance of moisture transforming from middle layers into surfaces of the sample increased which resulted in an increase of drying time. In accordance with the results, the final moisture content increased with the increase in the slice thickness. In other words, at the end of the drying process, the residual moisture content of the 7 mm thick sample was higher than that of the 3 mm thick samples. The final moisture content of the samples dried at 60°C was lower than that of those dried at 50°C, followed by those dried at 40°C and 30°C, due to the energy required to remove the water or to increase the vapour pressure of the product. These results are in agreement with the results of Khazaei *et al.*, [26] for thin-layer drying of carrot slices, and Nguyen and Price [27] for thin-layer drying of banana slices. Similar results are also reported by Sacilic and Elicin [28]. Also, it has been stated that the final moisture content of samples in dried aromatic plants should be between 5-10%; therefore, relevant drying method is necessary for increasing the quality of these products [28]. Accordingly, Arabhosseini *et al.* [29] stated that higher temperature caused shorter drying time, also, they indicated that leaves with fewer thicknesses need a shorter drying time compared to other thicknesses.

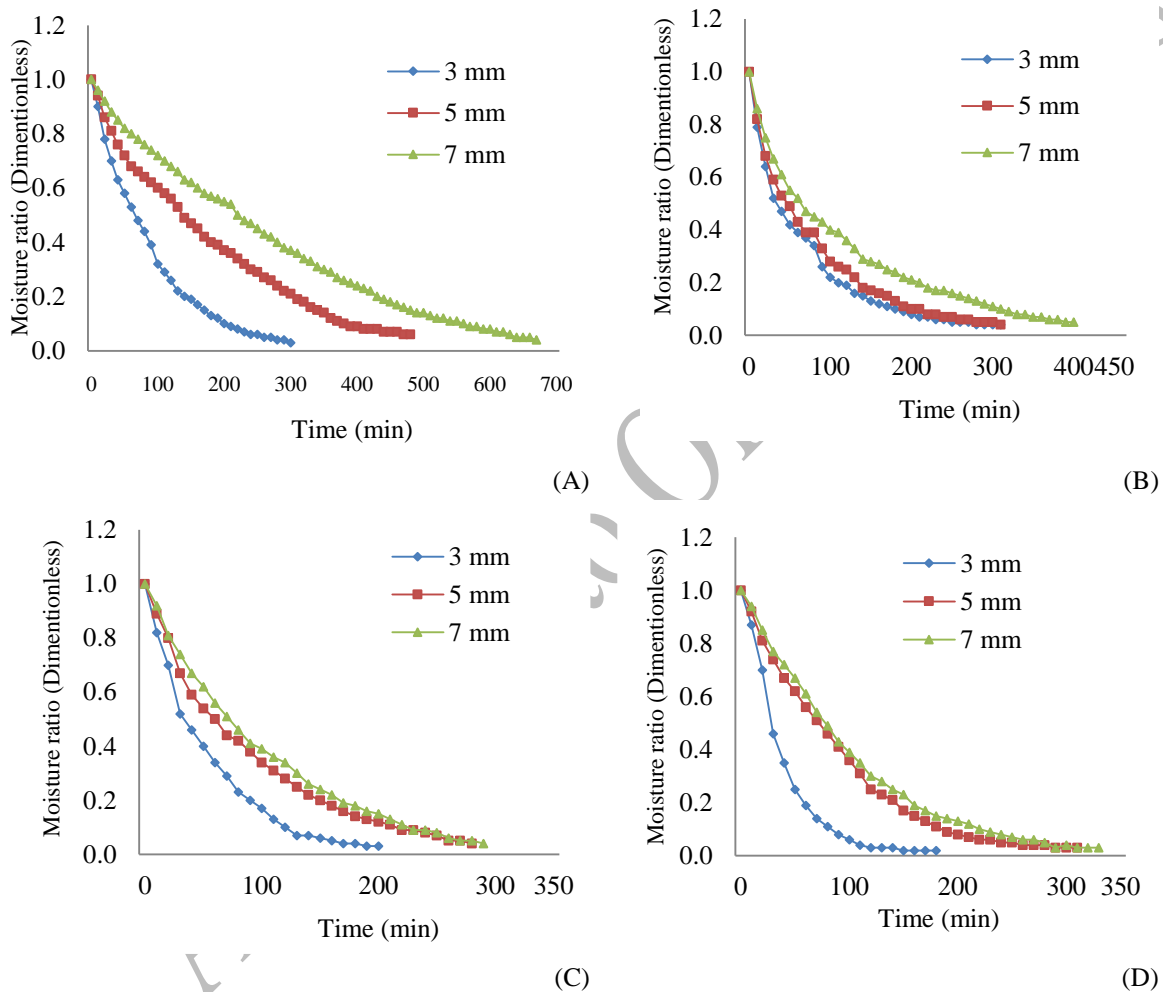

**Fig. 4** The moisture ratio of *Euphorbia condylocarpa* root slices during drying at air velocity of 0.5 m. s<sup>-1</sup>, thicknesses of 3, 5, and 7 mm and temperatures of A) 30 °C, B) 40 °C, C) 50 °C and D) 60 °C.

The average drying time of the samples is shown in Fig. 5 for all thicknesses (3, 5, and 7 mm) and all drying air temperatures (30, 40, 50, and 60 °C).

The drying time decreased for about 53.33% when the temperature increased from 30 to 60 °C. In general, increasing temperature improved the drying rate for all samples. The changes in moisture ratio was significant

for different treatments [30]. In this study, the drying time decreased for about 31.72%, 22.78%, and 11.48% by increasing the temperature from 30 to 40, 40 to 50, and 50 to 60 °C, respectively. Other researchers are also reported comparable results [31].

According to Fig. 5, the maximum and minimum drying times were obtained for thicknesses of 7 mm and 3 mm, respectively. Increasing the thickness of the samples from 3 to 7 mm increased the drying time for about 1.81% because, it takes a longer time to remove the moisture from thicker samples than the thinner samples. These findings are in agreement with the obtained results by [16] for drying of banana slices. Other researchers have also reported similar results [28]. The results also showed that thin layer drying of *Euphorbia condylocarpa* roots by hot air dryer was significantly different compared to the samples dried in open-air sun drying as the control treatment (Fig. 5).

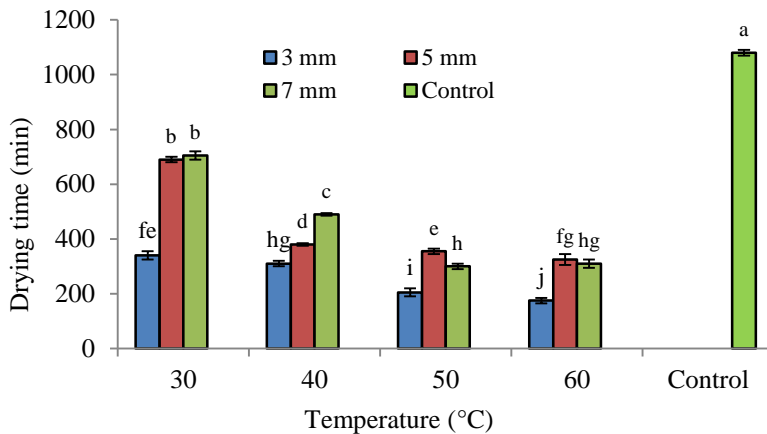

**Fig. 5** Interaction of temperature and thickness of root slices of *Euphorbia condylocarpa* for drying kinetics. (Non-similar letters means significant difference at  $p < 0.01$ ).

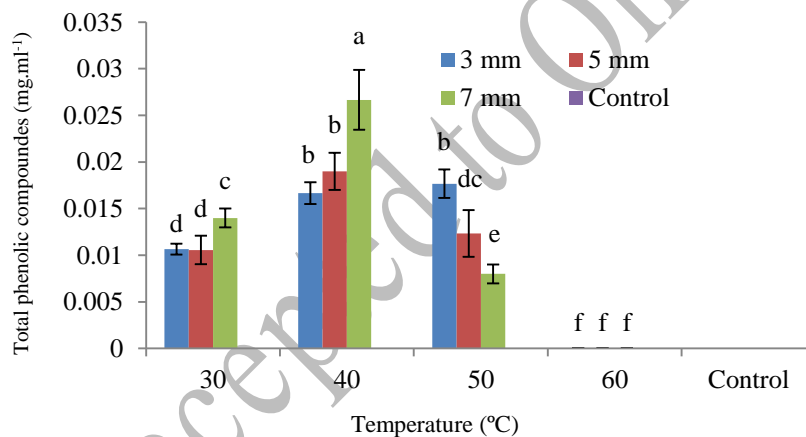

**Fig. 6** Interaction of temperature and thickness on the change of total phenolic compounds (TPC). (Non-similar letters means significant difference at  $p < 0.01$ ).

### Effect of Temperature and Thickness on TPCs

Phenolic compounds, as a part of the plant antioxidant compounds, are important essential oils of medicinal plants, which are affected by environmental factors, growth conditions, and post-harvest operations [32]. The effect of drying on phenolic compounds have already been investigated in various studies [33]. Wojdyło *et al.* [34] stated that drying temperature had a significant effect on the content of phenolic compounds and antioxidant activity of various plants. Furthermore, it is reported that the effect of temperatures on the content and formation of phenolic compounds may be due to the availability of phenolic precursors and non-enzymatic exchanges between the molecules [35]. Also, it has been pronounced that the increase in antioxidant activity following by

heat treatment resulted in the release of phenolic compounds and the formation of new compounds with high antioxidant properties [36].

The effect of temperature, thickness, and their interaction on changes of total contents of phenolic compounds showed a significant difference. As can be seen in Fig. 6, the highest content of phenolic compounds ( $0.0267 \text{ mg.ml}^{-1}$ ) was obtained for the thickness of 7 mm at temperature of  $40^\circ\text{C}$ , and the lowest content values were achieved for all thicknesses at temperature of  $60^\circ\text{C}$  and also for the control treatment (no compound). In general, it was also observed that the total phenolic compounds increased with increasing temperature from  $30^\circ\text{C}$  to  $40^\circ\text{C}$  but it was decreased by increasing temperature from  $40^\circ\text{C}$  to  $50^\circ\text{C}$ . Furthermore, the results of Fig. 6 statically indicated no significant differences between the contents of phenolic compounds under the interactions of temperatures of 30 and  $40^\circ\text{C}$  and thicknesses of 3 and 5 mm. There was a notable increase in the contents of phenolic compounds for the interaction of thickness of 7 mm and temperature of  $40^\circ\text{C}$  compare to the other interactions (Fig. 6).

Confirming the negative effects of high temperament on the content of essential oils, Arabhosseini *et al.* [37] stated that the essential oil contents of plants can be affected during drying. Therefore, in their study, tarragon plant leaves were dried at air temperatures of 40 to  $90^\circ\text{C}$  to evaluate the effects of temperature on the content of essential oils. Their results indicated that the content of essential oil had direct and negative correlations with high temperatures. The effect of different drying methods has also been studied on essential oils of different plants, such as *Matricaria chamomilla* [38], *Thymus daenensis* [39], and *Ocimum basilicum* [40], which showed similar outcomes.

### Effect of Temperature and Thickness on DPPH

The results of the ANOVA showed that the effects of temperature and thickness on DPPH free radical inhibition were significant difference ( $p < 0.01$ ). The results (Fig. 7) indicated that the highest free radical scavenging capacity of DPPH was observed in the samples with 5 mm thickness (an average of  $844.72 \text{ ml ex.g}^{-1}$ ). Furthermore, regarding to the effects of temperature on the changes of DPPH, the results indicated that the highest free radical scavenging capacity of DPPH with an average of  $840.18 \text{ ml ex.g}^{-1}$  was obtained at temperature of  $60^\circ\text{C}$ , and the lowest value for the mentioned trait was achieved at temperature of  $30^\circ\text{C}$  with an average value of  $687.69 \text{ ml ex.g}^{-1}$ .

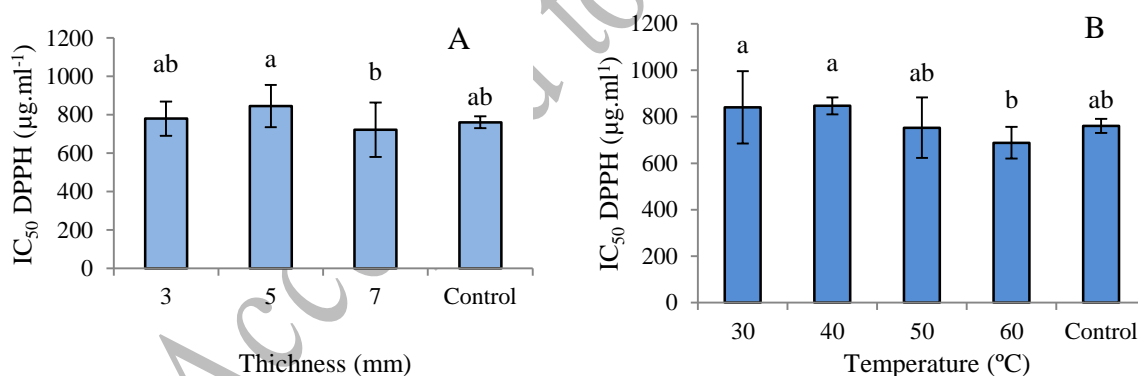

**Fig. 7** Changes of DPPH A) for different thicknesses and B) at different temperatures. (Non-similar letters means significant difference at  $p < 0.01$ ).

Since there are various antioxidant compounds in the root of the *Euphorbia condylocarpa*, the inconsistency of the phenolic compounds rate with the free radical scavenging capacity of DPPH may be due to the presence of other antioxidant compounds except for the polyphenol compounds. There are other researches, concerning the decrease of antioxidant properties and phenolic content in plant samples, especially vegetables, under heat treatments that often had attributed to a decrease in enzyme content and enzyme activity that these results confirm the results of the present study [36].



## Effect of Temperature and Thickness on Antimicrobial Properties

In this study, evaluation of antibacterial effects of *Pseudomonas aeruginosa* and *Staphylococcus aureus* on Muller Hinton Agar medium showed that the inhibition of gram-negative and gram-positive bacteria significantly affected by all treatments of temperature, thickness, and their interaction at  $p < 0.01$ .

Investigating the temperature and thickness interaction revealed that the highest diameter for inhibition of gram-positive bacterium of *Staphylococcus aureus* was observed for temperature of 50 °C and thickness of 3 mm interaction, with a significant difference compared to the other interactions (Fig. 8-A). Contrarily, the lowest inhibition (with no visible data) was obtained for the interaction of 60 °C and thickness of 7 mm.

The mean comparison of temperature and thickness interaction showed that the maximum inhibition zone values for the gram-negative *Pseudomonas aeruginosa* jointly belong to the samples dried at temperature of 60 °C and thickness of 3 mm and also temperature of 50 °C and thickness of 3 mm which was significantly different than the obtained inhibition zone values of the other interactions. Furthermore, it was observed that the notable minimum inhibition zone values (with no visible data) were for the interactions of 60 °C temperature and thickness of 5 mm and 7 mm (Fig. 8-B).

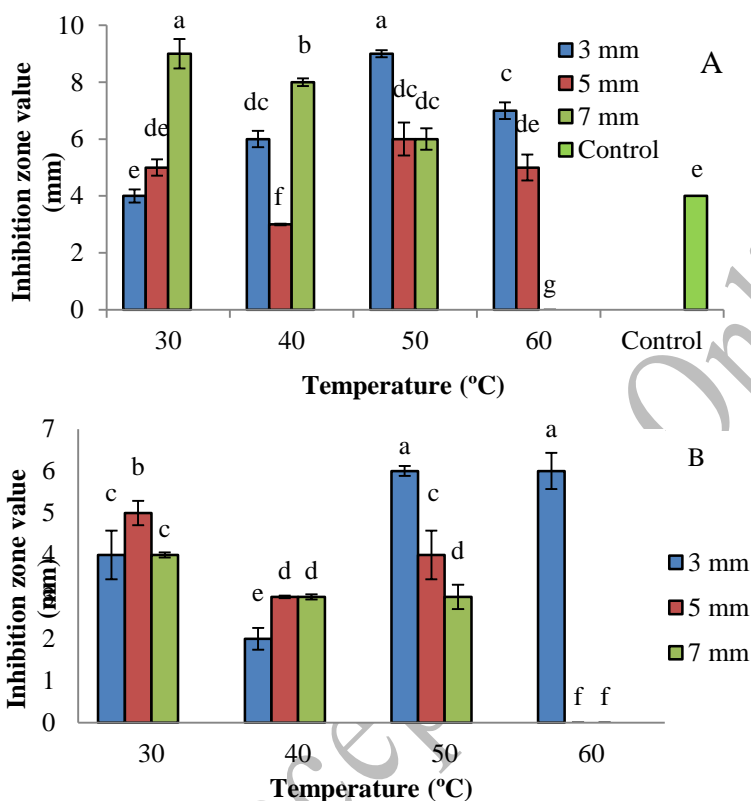

**Fig. 8** Interaction of temperature and thickness on inhibiting A) gram-positive bacterium of *Staphylococcus aureus* B) gram-negative bacterium of *Pseudomonas aeruginosa*. (Non-similar letters means significant difference at  $p < 0.01$ ).

## CONCLUSION

According to the results of the present study, no uniform drying rate was observed for the thin-layer drying process of *Euphoria Condylcarpa* roots. Drying time showed a significant difference at the studied temperatures and the thickness of the samples. The results showed that the required time increased by increasing thickness and decreasing temperature for the drying of *Euphoria Condylcarpa* roots. The total phenolic compounds increased when the temperature increased from 30 to 40 °C, and the increase of the free radical scavenging capacity of DPPH occurred when the temperature increased up to 60 °C. The highest contents of phenolic compounds and inhibition of free radical scavenging capacity of DPPH were obtained from the samples with the highest thickness

(7 mm). The highest inhibition zone values for the gram-positive bacterium of *Staphylococcus aureus* was achieved for the samples dried at 50 °C with 7 mm thickness and the highest inhibition zone values for gram-negative bacterium of *Pseudomonas aeruginosa* was observed in the samples with thickness of 3mm, dried at temperature of 50 °C. Accordingly, it is advised to dry *Euphorbia Condylcarpa* root slices with thickness of 7mm at 40 °C temperature that could be the appropriate conditions for packaging, marketing, nutritional value and antioxidant activity of this product.

## ACKNOWLEDGMENT

Authors would like to appreciate University of Tehran, college of Abouriahan for their supports.

## Declaration of Interest

The authors declare no competing interest.

## REFERENCES

1. Arabhosseini A., Huisman W., van Boxtel A., Müller J. Long-term effects of drying conditions on the essential oil and color of tarragon leaves during storage. *J Food Engineering*. 2007; 79 (2): 561-566.
2. Theodoridis S., Drakou E.G., Hickler T., Thines, M., Nogues-Bravo D. Evaluating natural medicinal resources and their exposure to global change. *Lancet Planet Health*. 2023; 7: e155–163.
3. Getachew S., Medhin G., Asres A., Abebe G., Ameni G. Traditional medicinal plants used in the treatment of tuberculosis in Ethiopia: A systematic review. *Heliyon*. 2022; 8: e09478.
4. Bijekar S., Gayatri M.C. Ethanomedicinal properties of euphorbiaceae family-A comprehensive review. *International Journal of Phytomedicine*. 2014; 6 (2): 144-156.
5. Mohammadi S., Asgary V., Sadat Shandiz S.A., Heidari E., Jozaghkar H., Ahangari Cohan R., Mirzaie A. Antimicrobial activity of methanolic root extract of *Euphorbia Condylcarpa* against pathogenic bacteria. *Advanced Studies in Biology*. 2015; 7 (2): 55-64.
6. Mohammadi S., Sadat Shandiz S.A., Bigdeli R., Mahboubi A., Hedayati M., Asgary V. Evaluation of anti-bacterial properties of *Euphorbia condylcarpa* methanol extract. *Archives of Microbiology and Immunology*. 2016; 1 (1): 12-20.
7. Jafri S.A.A., Khalid Z.M., Khan M.R., Ashraf S., Ahmad N., Karami A.M., Rafique E., Ouladsmene M., Al Suliman N.M.S., Aslam S. Evaluation of some essential traditional medicinal plants for their potential free scavenging and antioxidant properties. *Journal of King Saud University – Science*. 2023; 35: 102562.
8. El-Zayat M.M., Eraqi M.M., Alfaiz F.A., Elshaer M.M. Antibacterial and antioxidant potential of some Egyptian medicinal plants used in traditional medicine. *Journal of King Saud University – Science*. 2012; 33: 101466.
9. Mohammadi S., Mahboubi A., Mohammadi M., Hedayati M., Jalili A. Assessing the anticancer effect of the *Euphorbia condylcarpa* plant on ags gastric cancer cell line. *Gene, Cell and Tissue*. 2017; 4 (1): e41223.
10. Ramezani M., Behravan J., Arab M., Farzad S.A. Antiviral activity of *Euphorbia helioscopia* extract, *J. Biol. Sci*. 2008; 8 (4) 809-813.
11. Loureiro J., Campos A., Paulino U. Albuquerque Indicators of conservation priorities for medicinal plants from seasonal dry forests of northeastern Brazil. *Ecological Indicators*. 2021; 121: 106993.
12. Ebadi M., Azizi M., Sefidkon F., Ahmadi N. Influence of different drying methods on drying period, essential oil content and composition of *Lippia citriodora* Kunt. *Journal of Applied Research on Medicinal and Aromatic Plants*. 2015; 2 (4): 182-187.
13. Wang Y., Zhao Y., Liu X., Li J., Zhang J., Liu D. Chemical constituents and pharmacological activities of medicinal plants from Rosa genus. *Chinese Herbal Medicines*. 2022; 14: 187–209.
14. Müller J., Heindl A. Drying of medicinal plants. In: Boger, R.J., Craker L.E., Lange D. (Eds.), *Medicinal and Aromatic Plants*. Springer, New York, 2006.
15. Thuy Pham H.N., Nguyen T.V., Van Vuong Q., Bowyer M.C. Scarlett C.J. Effect of extraction solvents and drying methods on the physicochemical and antioxidant properties of *Helicteres hirsuta* leaves. *Technologies*. 2015; 3: 285-301.
16. Nguyen V.T. Duong Le M. Influence of Various Drying Conditions on Phytochemical Compounds and Antioxidant Activity of Carrot Peel. *Beverages*. 2018; 4 (4): 80-92.
17. de Aquino Brito Lima-Corrêa R., dos Santos Andrade M., da Silva M., Freire J., Ferreira M. Thin-layer and vibrofluidized drying of basil leaves (*Ocimum basilicum* L.): analysis of drying homogeneity and influence of drying

- conditions on the composition of essential oil and leaf colour. *Journal of Applied Research on Medicinal and Aromatic Plants*. 2017; 7: 54-63.
18. Sefidkon F., Abbasi K., Bakhshi Khaniki Gh. Influence of drying and extraction methods on yield and chemical composition of the essential oil of *Satureja hortensis*. *Food Chemistry*. 2006; 99: 19-23.
  19. Hamrouni Sellami, I. Wannas, W.A. Bettaieb I., Berrima S., Chahed T., Marzouk B., Limam F. Qualitative and quantitative changes in the essential oil of *Laurus nobilis* L. leaves as affected by different drying methods *Food Chemistry*. 2011; 101: 995–998.
  20. Asekun T., Grierson D.S., Afolayan A.J. Effects of drying methods on the quality and quantity of the essential oil of *Mentha longifolia* L. subsp. *Capensis* O. *Food Chemistry*. 2017; 101: 995–998.
  21. Aghbashlo M., Kianmehr M.H., Arabhosseini A. Energy and Exergy Analyses of Thin-Layer Drying of Potato Slices in a Semi-Industrial Continuous Band Dryer. *Drying Technology*. 2008; 26: 1501–1508.
  22. Aghbashlo, M. Exergetic simulation of a combined infrared-convective drying process. *Heat Mass Transfer*. 2016; 52: 829-844.
  23. Abbaspour-Gilaneh Y., Jahanbakhshi A., Kaveh M. Prediction kinetic, energy and exergy of quince under hot air dryer using ANNs and ANFIS. *Food Science & Nutrition*. 2020; 8 (1): 594-611.
  24. Aghbashlo M., Kianmehr M.H. Arabhosseini A. Modeling of thin-layer drying of potato slices in length of continuous band dryer, *Energy Conversion and Management*. 2009; 50: 1348–1355.
  25. Wayne P.A. Methods for dilution antimicrobial susceptibility tests for bacterial that grow aerobically, National committee for clinical laboratory standards (NCCLS). Document M7-A6, Clinical and Laboratory Standards Institute Pennsylvania 2006.
  26. Khazaei J., Chegini G.R., Bakhshiani M. A novel alternative method for modeling the effects of air temperature and slice thickness on quality and drying kinetics of tomato slices. Superposition technique. *Drying Tech*. 2008; 26(6): 759-775.
  27. Nguyen H.M., Price E.W. Air drying of banana: Influence of experimental parameters, slab thickness, banana maturity and harvesting season. *Journal of Food Engineering*. 2007; 79: 200-207.
  28. Sacilic K., Elicin A. Mathematical modeling of solar tunnel drying of thin layer organic tomato. *Journal of Food Engineering*. 2006; 73 (3): 231-238.
  29. Arabhosseini A., Huisman W., van Boxtel A., Muller J. Modeling of thin layer drying of tarragon (*Artemisia dracunculus* L.). *Industrial Crops and Products*. 2009; 29 (1): 53-59.
  30. Abasi S., Mousavi S.M., Mohebi M., Kiani S. Effect of time and temperature on moisture content, shrinkage, and rehydration of dried onion. *Iranian Journal of Chemical Engineering*. 2009; 6 (3): 57-70.
  31. Midili A., Kucuk H. Mathematical modeling of thin layer drying of pistachio by using solar energy. *Energy Conversion and Management*. 2003; 44 (7): 1111-1122.
  32. Saeedi K.A., Omidbaigi R. Determination of phenolics, soluble carbohydrates, carotenoid contents and minerals of dog rose (*Rosa canina* L.) fruits grown in South-West of Iran. *Iranian Journal of Medicinal and Aromatic Plants*. 2009; 25 (2): 203-215.
  33. Ismail A., Marjan Z.M., Foong C.W. Total antioxidant activity and phenolic content in selected vegetables. *Food Chemistry*. 2004; 87 (4): 581-586.
  34. Wojdylo A., Lech K., Nowicka P., Hernandez F., Figiel A., Carbonell-Barrachina A.A. Influence of Different Drying Techniques on Phenolic Compounds, Antioxidant Capacity and Colour of *Ziziphus jujube* Mill. *Fruits. Molecules*. 2019; 24 (13): 2361.
  35. Que F., Mao L., Fang X. Wu T. Comparison of hot air-drying and freeze-drying on the physicochemical properties and antioxidant activities of pumpkin (*Cucurbita moschata* Duch.) flours. *International Journal of Food Science and Technology*. 2008; 43 (7): 1195-1201.
  36. Tomaino A., Cimino F., Zimbalatti V., Venuti V., Sulfaro V., De Pasquale A., Saija A. Influence of heating on antioxidant activity and the chemical composition of some spice essential oils. *Food Chemistry*. 2005; 89 (4): 549-554.
  37. Arabhosseini A., Padhye S., van Beek T.A., van Boxtel A.J.B., Huisman W., Posthumus M.A., Muller J. Loss of essential oil of tarragon (*Artemisia dracunculus* L.) due to drying. *Journal of the Science of Food and Agriculture*. 2006; 86: 2543-2550.
  38. Din R.U., Amin M., Shad A.A., Shah S., Rahman M.U., Uddin S., Hanif M., Ali S. Effect of different drying methods on the essential oil contents of *Matricaria chamomilla* flower; A medicinal plant. *Pakistan journal of weed science research*. 2016; 22 (1): 69-79.
  39. Rahimmalek M., Goli S.A.H. Evaluation of six drying treatments with respect to essential oil yield, composition and color characteristics of *Thymys daenensis*. *Celak Leaves. Industrial Crops and Products*. 2013; 42 (1): 613-619.

40. Hassanpouraghdam M.B., Hassani A., Vojodi L., Farsad-Akhtar N. Drying Method Affects Essential Oil Content and Composition of Basil (*Ocimum basilicum* L.). Journal of Essential Oil Bearing Plants. 2010; 13 (6): 759-766.

Accepted to Online Publish